

Avitech International Corporation
www.avitechvideo.com

The True Story about rotating an Image 90°

Rotating the output 90 degrees⁻¹

- The advantage
 - If the LCD/Plasma is 42" or smaller, it will fit in the rack and save some space

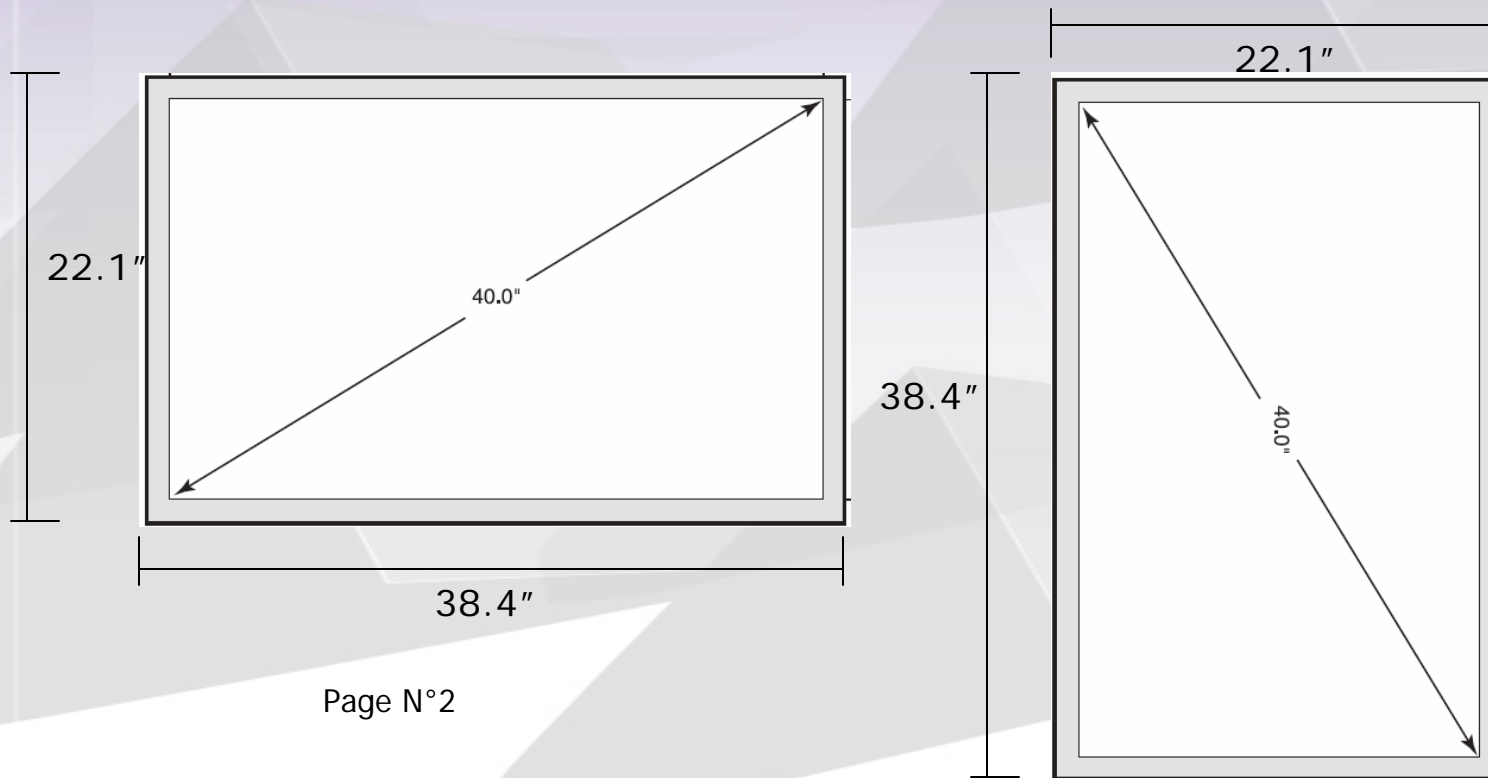

Rotating the output 90 degrees⁻²

- The disadvantage
 - It adds delay to the image processing
 - Images must be read into a frame store and played back out in a different order. This adds at least 1 to 2 frames.
 - Not suitable for production
 - Lower resolution
 - Added cost for this option and overall system

The Process

- Writing to memory and reading it back out in a different direction takes at least 1 or 2 frame(s) of processing time

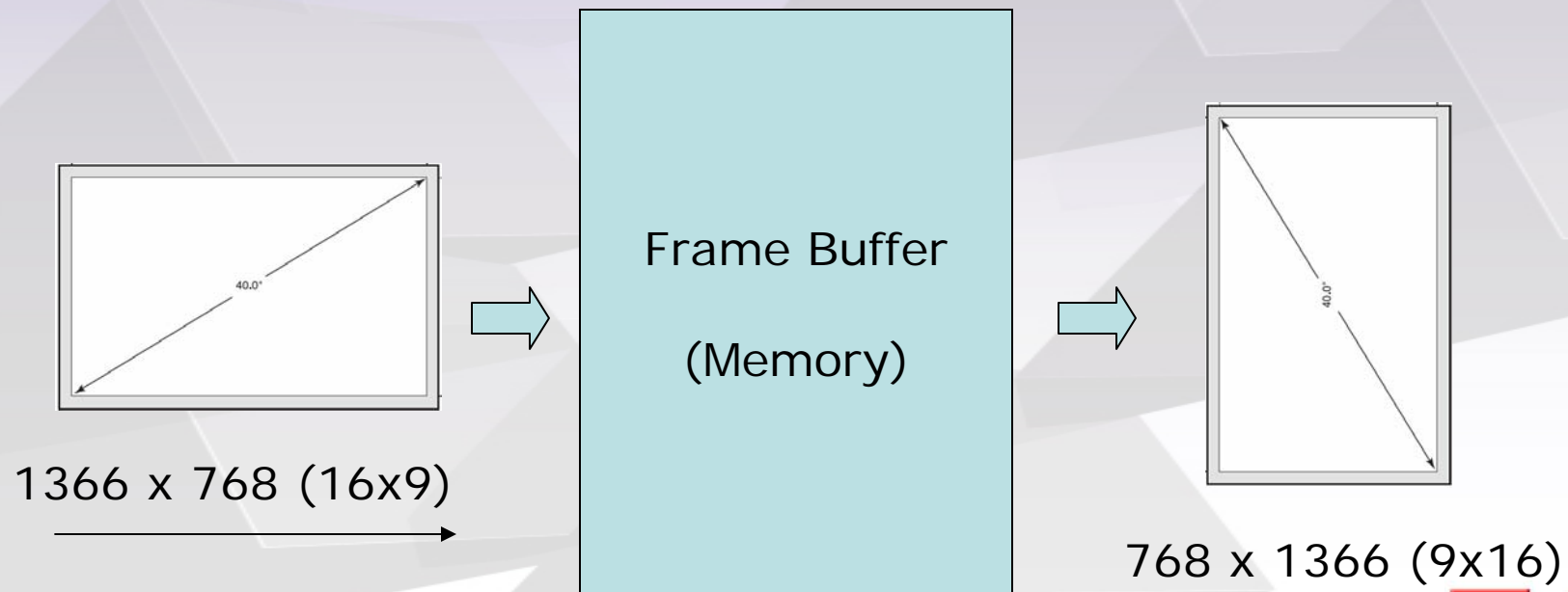

The resolution issue

- The Resolution is lower
- The Aspect Ratio is wrong

Resolution: 768x1366
Aspect Ratio: 9x16

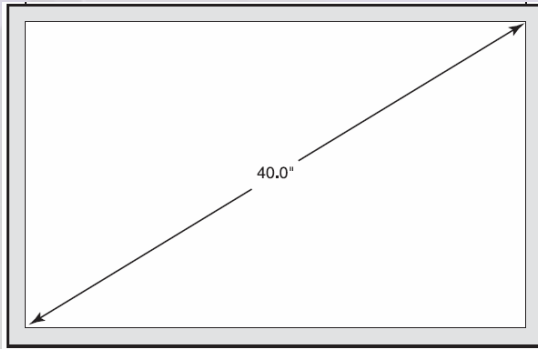

Resolution: 1366x768
Aspect Ratio: 16x9

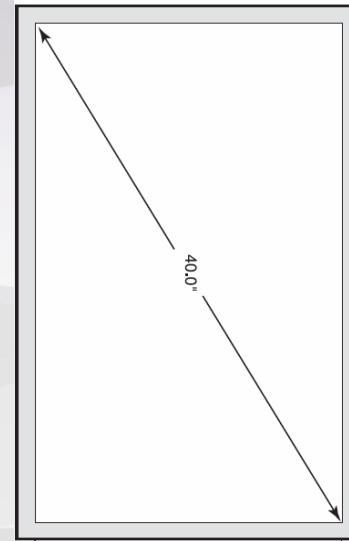

A Real Life Example⁻¹

- A layout with 17 inputs and 2 clocks at 40" and 16x9

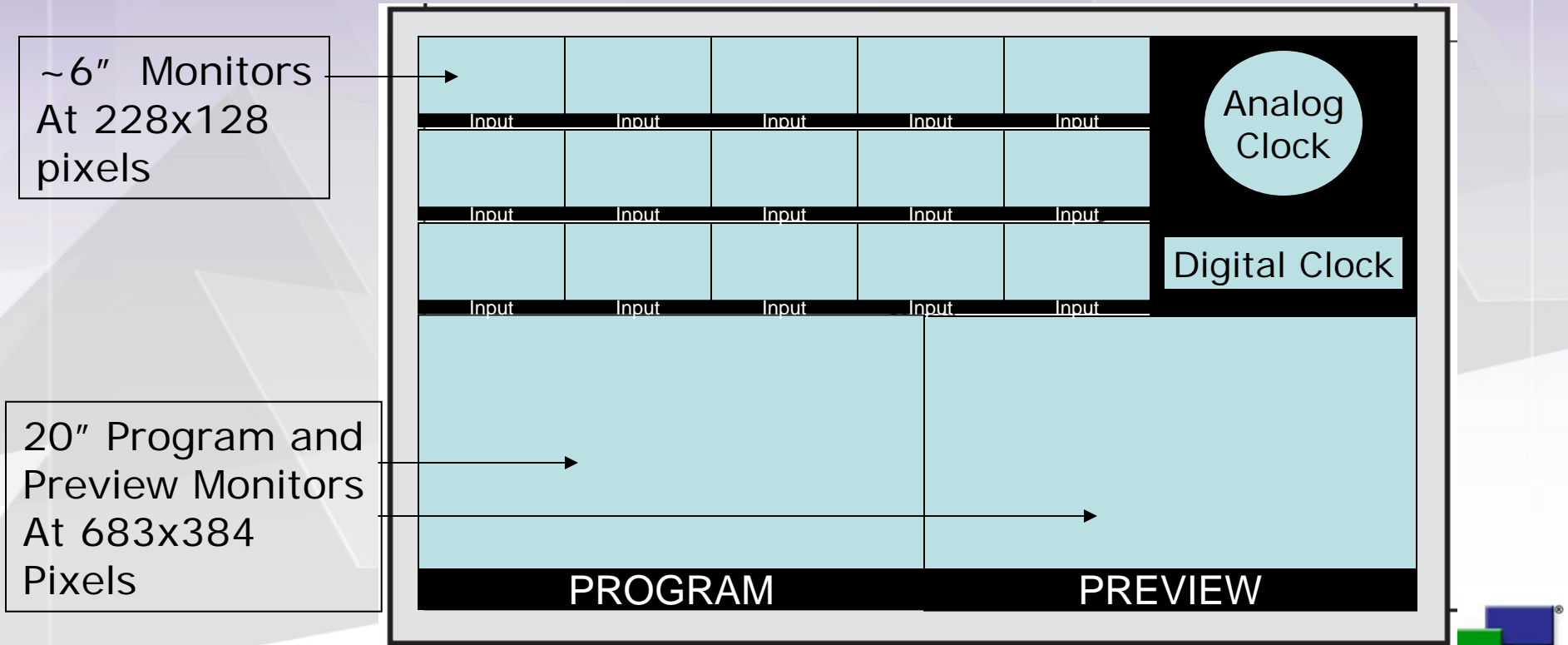

A Real Life Example⁻²

- 17 inputs at 40" and 9 x 16

9" Program and Preview Monitors
At 307x175
Pixels

~6" Monitors
At 228x128
pixels

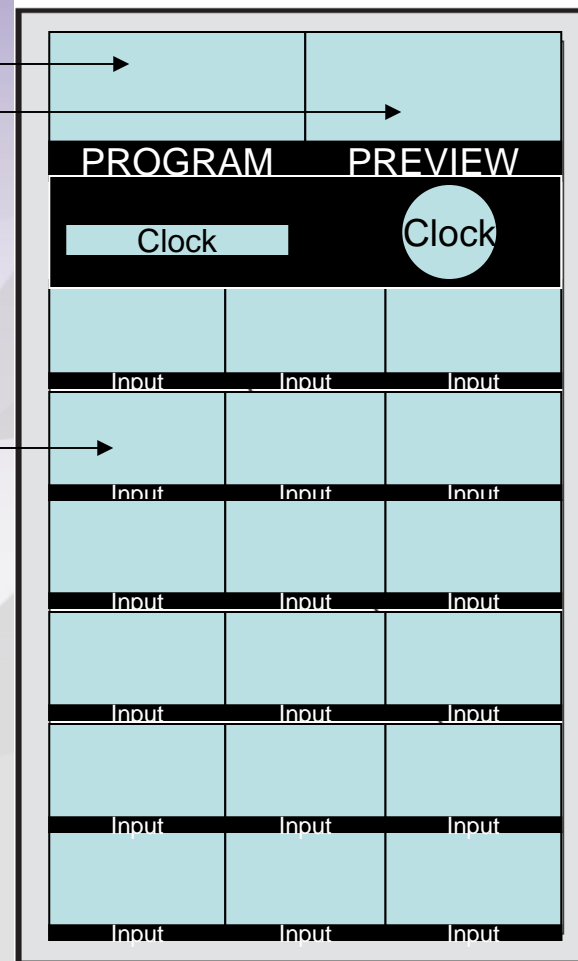

An Alternative Solution⁻¹

- 2 x 24" LCD Monitor



15.27"

22"

1920x1200 Resolution



15.27"

22"

1920x1200 Resolution

An Alternative Solution⁻²

- 2 x 24" LCD Monitors stack on top of each other



An Alternative Solution⁻³

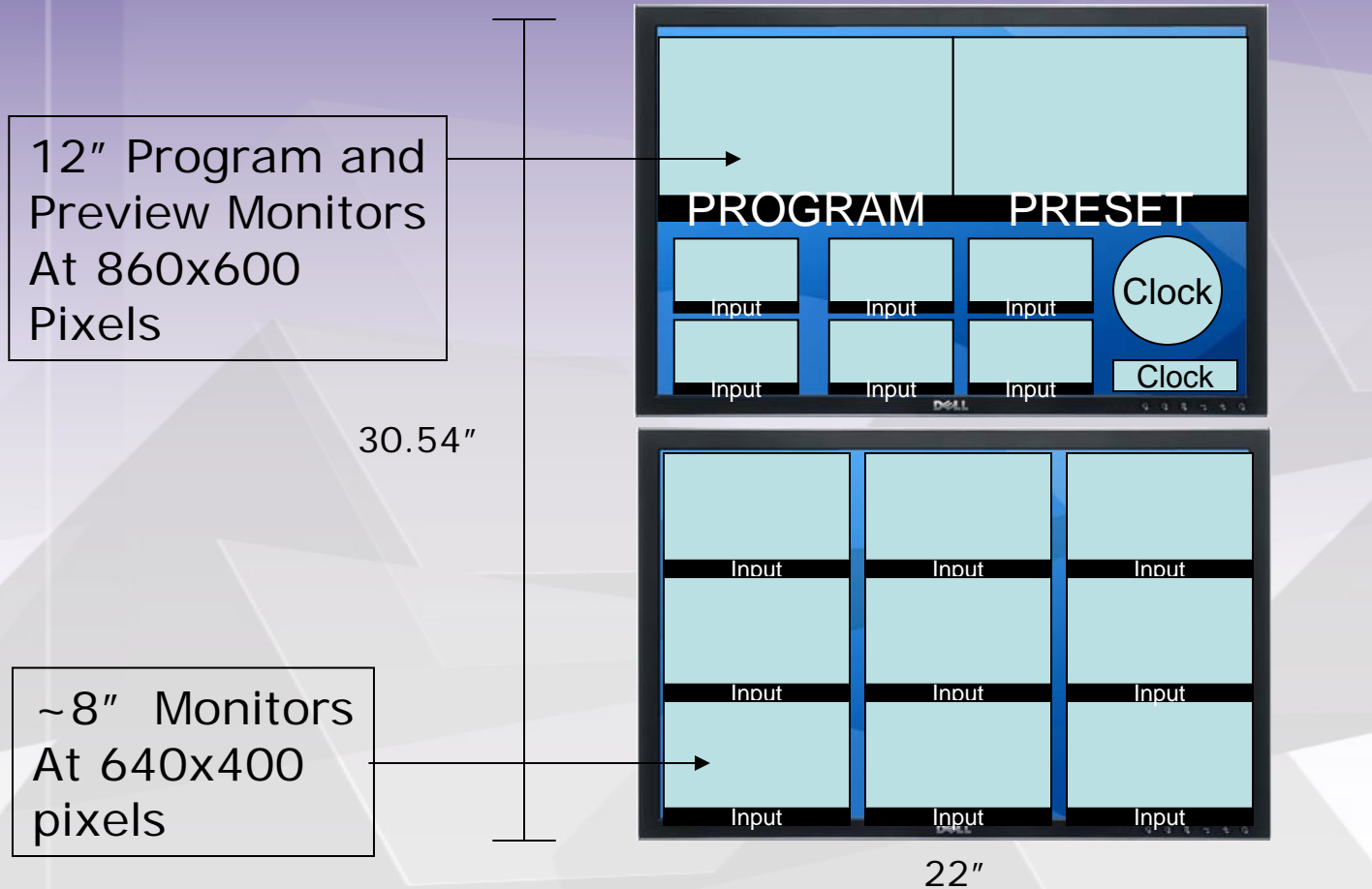

Summary Comparison

	40" LCD in Portrait Mode	2 x 24" LCD on top of Each Other
Height	38.4"	30.54"
Width	22.1"	22"
Aspect Ratio	9 x 16	2 x (16x9)
Resolution per Windows	9" Window @ 307 x 175	12" Window @ 860x600
Total Display Resolution	768 x 1366	3840 x 2400
Cost	~\$4,000*	~\$1,600*
Added Processing Delay	1 to 2 frames	None
Added cost for processing	\$\$??	None

* The monitors used in this comparison is the Clarity Bobcat and Dell 24" LCD

Summary

- Instead of turning a 40+ " 16x9 display 90 degrees to an unnatural aspect ratio and position for displaying video, 2 x 24" LCD monitor has the following advantages
 - Shorter Height and Width
 - Better viewing angle
 - Less Processing delay
 - Better combined resolutions
 - More cost effective